

# Dynamic Cylinder Deactivation

Adarrsh Paul<sup>1</sup>, Rajat Kumar Singh<sup>2</sup>, Jayant Singh<sup>3</sup>, Akkshansh Paul<sup>4</sup>, R. Angeline<sup>5</sup>

<sup>1, 2, 3, 4</sup> Student, Computer Science and Engineering, SRM University Ramapuram, Chennai, India.

<sup>5</sup> Assistant Professor, Computer Science and Engineering, SRM University Ramapuram, Chennai, India.

**Abstract** – Automobile contains multiple cylinders to produce power to run the vehicle. Every drop of fuel in the combustion chamber produces the same amount of power everytime irrespective of the power needed to run the vehicle. There are times when a car is stuck in traffic and it won't be able to use the full potential of the car, so in this case we waste fuel. In order to overcome this problem we can use the method of cylinder deactivation in which the pistons get deactivated and only limited amount of pistons keep working enough to give power to the vehicle. Using this we can save fuel everytime we get stuck in traffic. An ECU decides when the cylinder should get deactivated or activated. Thus making the whole process automatic and easy.

## 1. INTRODUCTION

Modern automotive engines (both SI and CI) are complex systems that pose several multiobjective, multiconstraint problems from an engine control and optimization standpoint. These are largely due to the ever-increasing demand for higher power output, increased fuel economy, and reduced emissions. Real-time control of IC engines poses even greater challenges in terms of computational cost, robustness of the control algorithms, and fidelity of the underlying physical models. Given the large parameter space (engine geometry, engine RPM, air-fuel-ratio, spark/fuel injection timing, etc.) over which an engine has to be optimized for performance and emissions, formulation of a generalized mathematical optimization problem can be difficult.

Typically, design engineers focus on examining localized regions of the overall operating parameter space in order to evaluate the relative effect of changing one particular parameter with respect to another. For instance, one could pose questions such as what is the minimum percent reduction in engine torque needed in order to obtain a 2 percent reduction in fuel consumption? or what is the percent increase in overall engine-out NO/CO for a 5 percent increase in overall average torque over a typical driving cycle? Design, optimization, and control of conventional engines can be carried out by using available engine data.

For newer engine concepts and/or operating regimes and for engines powered by alternative fuels or fuel blends, one can complement limited engine data through the use of reliable physics-based engine models for making design and/or optimization decisions. Development of reliable, physics-based engine modeling tools can thus play an integral role in the design and optimization studies of engines. according to the use.

## 2. VARIABLE CYLINDERS MANAGEMENT

The working principle of the variable cylinders management was shown in figure 5. Under partial load conditions, the fuel consumption increased significantly. But the gasoline engines operated often under part-load conditions. They wasted a huge amount of energies. In order to enhance the engine load rate, the variable cylinder management was used. In other words, the number of the working cylinders in engine was variable. All cylinders operate under the full-load conditions. But under the part load conditions only partial cylinders operated and others didn't work. So the engine displacements varied with the different load rate. It made engines with better dynamic performance and fuel economy. A switch valve was set in the engine. When some cylinders didn't work, the switch valve was opened. The exhaust gas was introduced into these cylinders to keep the high temperatures. Now the variable cylinders management was applied mostly in the gasoline engine. According to many testing data, the technology had remarkable economization effect on fuel; ca.15% ~ 50% fuels could be saved. At present the concrete methods of variable cylinder management included :( 1) just cutting off the fuel supply of part of the cylinders. and with the fuel supply be cut off, a lot of fresh air flowed into the combustion chamber through the full opening throttle valve.(2) after cutting off a part of cylinders fuel injection, the exhaust gases were circulated instead of the fresh air.(3) closing the intake and exhaust valves of part cylinders ,stopping fuel and air supply. The main drawbacks of the technology were that the closed cylinders weren't used the reduced pressure measures and they would become the new load of the engines. This would waste some effective power.

## 3. PROPOSED SYSTEM AND SYSTEM ARCHITECTURE

The proposed system is unique as we are using lidar system to actuate the deactivation/activation process.

- a) First the lidar system will calculate the distance from obstacle. Suppose we say the obstacle is at 200 meters away from the source.
- b) The second step is to decide which cylinders are to be deactivated. This is decided with the help of ECU, which will be programed for optimum output. According to the ECU results the fuel supply of cylinder which are to be deactivated will be cut. Thus making them deactivated.

- c) Third step contains the use of Lidar again which will be calculating no obstacle and clean road in order to activate the cylinder which were deactivated earlier.

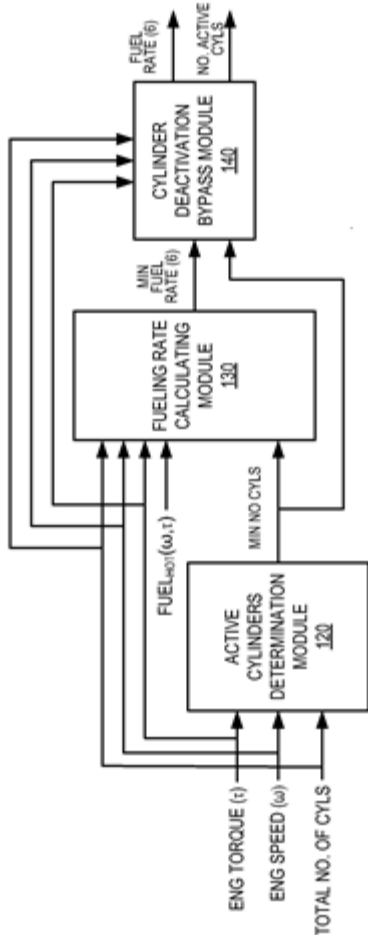

#### 4. IMPLEMENTATION

Implementing the systems will contain few add-ons of new technology like:-

- vvt(variable valve timing valves):- VVTL-i (Variable Valve Timing and Lamego intelligent system) (also sometimes denoted as VVT-iL or Variable Valve Timing and Intelligence with Lift) is an enhanced version of VVT-i that can alter valve lift (and duration) as well as valve timing. In the case of the 16 valve 2ZZ-GE, the engine head resembles a typical DOHC design, featuring separate cams for intake and exhaust and featuring two intake and two exhaust valves (four total) per cylinder. Unlike a conventional design, each camshaft has two lobes per cylinder, one optimized for lower rpm operation and one optimized for high rpm operation, with higher lift and longer duration. Each valve pair is controlled by one rocker arm, which is operated by the camshaft. Each

rocker arm has a slipper follower mounted to the rocker arm with a spring, allowing the slipper-follower to freely move up and down with the high lobe without affecting the rocker arm. When the engine is operating below 6000-7000 rpm (dependent on year, car, and ECU installed), the lower lobe is operating the rocker arm and thus the valves, and the slipper-follower is freewheeling next to the rocker arm. When the engine is operating above the lift engagement point, the ECU activates an oil pressure switch which pushes a sliding pin under the slipper-follower on each rocker arm. The rocker arm is now locked into the slipper-follower's movements and thus follows the movement of the high rpm cam lobe and will operate with the high rpm cam profile until the pin is disengaged by the ECU. The lift system is similar in principle to Honda VTEC operation.

- Torsional dampers:- Torsional vibration is a concern in the crankshafts of internal combustion engines because it could break the crankshaft itself; shear-off the flywheel; or cause driven belts, gears and attached components to fail, especially when the frequency of the vibration matches the torsional resonant frequency of the crankshaft. Causes of the torsional vibration are attributed to several factors.

Alternating torques are generated by the slider-crank mechanism of the crankshaft, connecting rod, and piston. The cylinder pressure due to combustion is not constant through the combustion cycle.

The slider-crank mechanism does not output a smooth torque even if the pressure is constant (e.g., at top dead centre there is no torque generated)

The motion of the piston mass and connecting rod mass generate alternating torques often referred to as "inertia" torques

Engines with six or more cylinders in a straight line configuration can have very flexible crankshafts due to their long length.

2 Stroke Engines generally have smaller bearing overlap between the main and the pin bearings due to the larger stroke length, hence increasing the flexibility of the Crankshaft due to decreased stiffness.

There is inherently little damping in a crankshaft to reduce the vibration except for the shearing resistance of oil film in the main and conrod bearings.

If torsional vibration is not controlled in a crankshaft it can cause failure of the crankshaft or any accessories that are being driven by the crankshaft (typically at the front of the engine; the inertia of the flywheel normally reduces the motion at the rear of the engine).

This potentially damaging vibration is often controlled by a torsional damper that is located at the front nose of the crankshaft (in automobiles it is often integrated into the front pulley). There are two main types of torsional dampers.

Viscous dampers consist of an inertia ring in a viscous fluid. The torsional vibration of the crankshaft forces the fluid through narrow passages that dissipates the vibration as heat. The viscous torsional damper is analogous to the hydraulic shock absorber in a car's suspension.

Tuned absorber type of "dampers" often referred to as a harmonic dampers or harmonic balancers (even though it technically does not dampen or balance the crankshaft). This damper uses a spring element (often rubber in automobile engines) and an inertia ring that is typically tuned to the first torsional natural frequency of the crankshaft. This type of damper reduces the vibration at specific engine speeds when an excitation torque excites the first natural frequency of the crankshaft, but not at other speeds. This type of damper is analogous to the tuned mass dampers used in skyscrapers to reduce the building motion during an earthquake.

Lidar sensors :- Lidar uses ultraviolet, visible, or near infrared light to image objects. It can target a wide range of materials, including non-metallic objects, rocks, rain, chemical compounds, aerosols, clouds and even single molecules. A narrow laser beam can map physical features with very high resolutions; for example, an aircraft can map terrain at 30-centimetre (12 in) resolution or better.

The essential concept of Lidar was originated by EH Synge in 1930, who envisaged the use of powerful searchlights to probe the atmosphere. Indeed, Lidar has since been used extensively for atmospheric research and meteorology. Lidar instruments fitted to aircraft and satellites carry out surveying and mapping – a recent example being the U.S. Geological Survey Experimental Advanced Airborne Research Lidar

NASA has identified lidar as a key technology for enabling autonomous precision safe landing of future robotic and crewed lunar-landing vehicles.

## 5. RESULT

This paper discussed the development of an integrated tool for the design, optimization, and real-time control of engines from a performance and emissions standpoint. The tool was used to conduct parametric studies of the impact of various operating

parameters such as load, engine-speed, equivalence ratio, and ignition timing on the engine performance (torque) and emissions (NO and CO).

## 6. CONCLUSION

Developing an effective controller for an engine with cylinder deactivation requires careful modification of the base controller functionality (torque structure, VCT scheduling), and the development of a mode selection and transition feature. The overall modification mostly focuses on key intermediate control parameters to allow an efficient controller architecture.

Key modifications were:

Use of torque per cylinder in the torque structure Features, which reduces calibration complexity and facilitates calculation of desired air charge, and manifold pressure in each operating mode. These are used to control VCT positioning in each mode and enable the mode transition design.

Use of an explicit hierarchical mode selection logic, which simplifies the implementation of diverse limiting factors on half cylinder operation.

This overall design minimizes modifications and calibration complexity without compromising vehicle performance in full cylinder mode, half cylinder mode and during mode transitions.

## 7. FUTURE SCOPE

In the coming future the type of cars we drive are going to change and dynamic cylinder activation is key to the future driving experience.

## ACKNOWLEDGMENTS

Mr. Jayant Singh, Mr. Rajat Singh, Mr. Adarrsh Paul, Mr. Akkshansh Paul would like to thank Prof Mrs. Angeline for his constant encouragement and help. His guidance in understanding the various aspects related to this project was vital.

## REFERENCES

- [1] Leone, T. G., Pozar, M., "Fuel economy benefit of cylinder deactivation-Sensitivity to vehicle application and operating constraints" SAE, SAE 200 1-0 1-359 1
- [2] Glugla, Christopher P.; Michelini, John Ottavio, "Temperature management of catalyst system for a variable displacement engine 'I, US Patent 6415601 B1
- [3] Glugla, Christopher P.; Michelini, John Ottavio, "Exhaust gas oxygen sensor temperature control for a variable displacement engine", US Patent 638 1953 B1